

# SINGLE PRESSURE AND DIFFERENTIAL PRESSURE DIGITAL MANOMETERS

Electronic Zeroing,  $\pm 1.5\%$  Accuracy

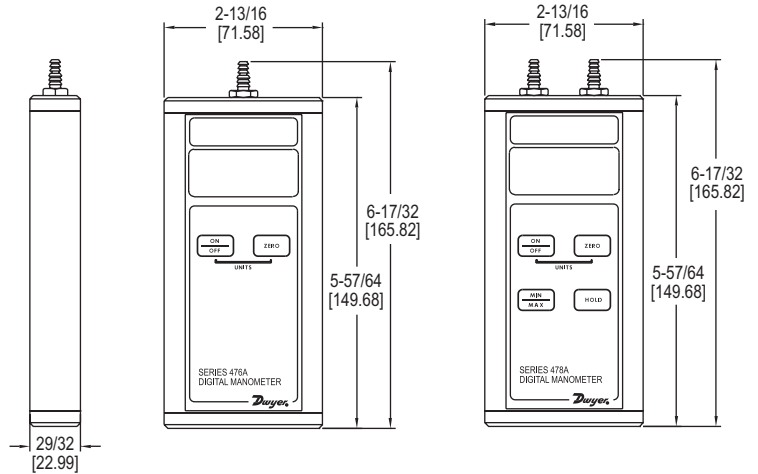

The **Series 476A Single Pressure Digital Manometer** can be used to measure low pressures from -20 to 20 in w.c. with  $\pm 1.5\%$  FS accuracy. The **Series 478A Differential Pressure Digital Manometer** can be used to measure positive, negative, or differential pressures. Both units are constructed of an extruded aluminum case for exceptional durability.

**FEATURES/BENEFITS**

- $\pm 0.5\%$  FS accuracy
- Rugged extruded aluminum housing
- One button auto-zero function
- Auto power off function to conserve battery life
- Instant selection of up to nine English/metric units

**APPLICATIONS**

- Verify field instrumentation performance
- Adjust fuel mixture on combustion systems

**SPECIFICATIONS**

**Service:** Air and compatible gases.  
**Wetted Materials:** Consult factory.  
**Accuracy:**  $\pm 1.5\%$  FS at 72°F (22.2°C). Includes linearity and repeatability.  
**Pressure Hysteresis:**  $\pm 0.1\%$  FS.  
**Pressure Limits:** 5 psig (.74 bar).  
**Temperature Limits:** 0 to 140°F (-17.8 to 60°C).  
**Compensated Temperature Limits:** 32 to 104°F (0 to 40°C).  
**Thermal Effect:** 0.05% FS/°F.  
**Display:** 4 digit LCD (.425"H x .234"W digits).  
**Power Requirements:** 9 V alkaline battery, installed non-functional, user replaceable.  
**Process Connections:** For use with 3/16" or 1/4" ID tubing.  
**Weight:** 10.8 oz (306 g).  
**Agency Approvals:** CE.

**MODEL CHART**

Model	Range in w.c.	Available Pressure Units								Resolution in w.c.	Maximum Pressure	
		bar	psi	in Hg	kPa	in w.c.	mm Hg	mbar	mm w.c.			Pa
476A-0	-20.0 to 20.0	.0498	0.723	1.471	4.98	20.00	37.4	49.8	508	-	0.02	5 psig
478A-0	-4.00 to 4.00	-	.1445	.294	0.996	4.00	7.47	9.96	101.6	996	0.01	5 psig
478A-1	-60.0 to 60.0	.1495	2.168	4.41	14.95	60.0	112.1	149.5	1524	-	0.1	5 psig

**OPTIONS**

To order add suffix:	Description
-NIST	NIST traceable calibration certificate
Example: 478A-1-NIST	

**ACCESSORIES**

Model	Description
A-402A	Carrying case, tough gray nylon pouch protects any Series 476A/478A manometer, double zippered for quick and easy access, belt loop that snaps closed, 7-1/2"H x 3"W x 2-1/4"D (191 x 76 x 57 mm)
UHH-C1	Soft carrying case
A-47X-BOOT	Protective magnetic rubber boot

