

70 Series High Temperature Stainless Steel Liquid Level Sensor

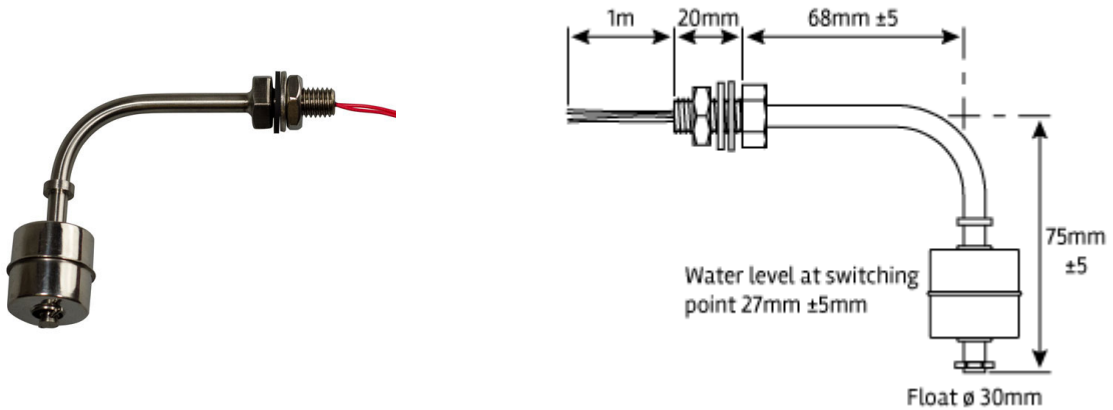

The 70 series is a small side mounted vertical liquid level sensor designed for high temperature/high pressure operation and sensing chemically aggressive liquids. The design provides a cost effective solution where high reliability in a demanding environment is called for. It is ideal for applications in food, automotive, pharmaceutical and chemical industries. As shipped, the float switch is Normally Open and closes on rising to the switching point. This can be changed to Normally Closed and open on rising by inverting the float on the stem. The high temperature version of the 70 series has the added benefit of being able to operate in temperatures exceeding the standard limit of 120°C and can operate in temperatures of up to 200°C.

Technical Data

Float Specific Gravity	0.62
Maximum Pressure	10 bar
Operating Temperature	-20°C to +200°C
Switch rating	Form A: 240Vac, 1Amp, 50Watts max
Cable length*	1 Metre
Cable Type	PTFE insulated 7/0.2
Weight	30g
Mounting	M10 x 20mm
Wetted Materials	316L Stainless Steel

*For custom length contact the sales office for advice

Switch Contact Ratings: are for pure resistive loads. For other loads i.e capacitive, inductive or incandescent lamps please contact Deeter for advice. This device must be earthed when used with hazardous voltages. For AC circuits ensure the peak voltage x current does not exceed the power rating.

70 Series High Temperature Stainless Steel Liquid Level Sensor

Ordering Information

DE70-50AH

DE70-50AH = 70 Series, Material Stainless Steel, 50 Watt float switch, Form A SPST, High Temperature.

All electrical equipment should be installed by a qualified/certified electrician.

The Deeter Group follows a policy of continual development of its products and reserves the right to change specifications and/or features without notice.