



Vision

Turbine Flow Meters

Turbine meter

Vision Series 1000

DESCRIPTION

The small turbine meter VISION measurement technology is ideal for the accurate measurement of low viscous and non-aggressive fluids. The VISION 1000 series is most suited for the measurement of flow rates from 0,1 to 2,5 l/min. The turbine meters can be mounted in any position.

MEASURING PRINCIPLE

Turbine meters are indirect volumetric meters. When the fluid passes through, a rotor is activated and the movement is either electronically or mechanically transmitted outside. The rotor is turned by the fluid force, proportional to the flow rate. A Hall effect sensor detects the passage of the rotor and supplies pulses, which can be utilized for digital or analogue signal processing. The generated pulses are specified as the K-factor. The large number of pulses provides high resolution. As the mass of the turbine is very small the response time is very short. It is not necessary to install a straight length of pipeline at the upstream side of the meter.



SPECIFICATIONS

Type	VISION 1005 2F66
-------------	------------------

Performance	
Flow rate	0.1 – 2.5 l/min
Accuracy	± 3% of reading
Repeatability	< 0,5% under the same operating conditions
Operating temperature	-20°C to 100°C
Operating pressure rate	max. 25 bar; with push-fit connection 10 bar (+20°C) and 7 bar (+65°C)
Burst pressure	200 bar

Pick up				
Pulse sensor	Hallsensor			
Input power	5 – 24 VDC			
Output signal	Open collector (NPN sinking) @ max. 20 mA, 1-2.2 kOhm pull up resistor required			
Power consumption	approx. 8 mA			
K-factor	Material	Nominal size	Flow range	K-factor
	Trogamid CX7323	5 mm	0.1 – 2.5 l/min	22000 pulse/liter
	Stainless steel, INOX 1.4401 / AISI 316	5 mm	0.1 – 2.5 l/min	24500 pulse/liter
	Grilamid LV-50H FWA	5 mm	0.1 – 2.5 l/min	22500 pulse/liter



Badger Meter

VIS-DS-03778-DE-01 (Oktober 2021)

Data sheet

Material	
Housing	Trogamid CX7323
	Stainless steel, INOX 1.4401 / AISI 316
	Grilamid LV-50H FWA nature, reinforced fiberglass
Rotor	PPS Ferrite bound
Bearings	2 PTFE / Graphite bearings

Fluids	
Viscosity	0.8 – 16 mm ² /sec (mPas/cST)
Fluid type	Liquids
Filter	20 to 40 micron recommended

Installation	
Nominal size DN	5 mm
Mounting position	In any orientation
Electrical connection	3 Pin (2.8 x 0.5) for MINI DIN Connector, EN 60529
	Round cable 3 x AWG 24 with free cable ends
IP Protection class (DIN Connector)	IP67
Mechanical connection	G 1/4" (Trogamid, Stainless steel, Grilamid reinforced fiberglass)
	NPT 1/4" (Trogamid)
	OD = 6mm, Push-fit (Grilamid reinforced fiberglass)
Tightening torque for screwed connection	approx. 6 Nm

Calibration (Optional)	
5-Point Calibration	@ Water, 20°C

Weight			
	Housing	Connector	Weight
	Trogamid CX7323	DIN	15 g
	Trogamid CX7323	1 m cable	30 g
	Stainless steel, INOX 1.4401 / AISI 316	DIN	60 g
	Grilamid LV-50H FWA, reinforced fiberglass	DIN	15 g
	Grilamid LV-50H FWA, reinforced fiberglass	DIN, push-fit connector	25 g
	Grilamid LV-50H FWA, reinforced fiberglass	1 m cable, push-fit connector	40 g

Approvals		
	Housing	Approvals
	Trogamid CX7323	KTW, NSF/ANSI 61, WRAS, ROHS, CE
	Stainless steel, INOX 1.4401 / AISI 316	KTW, ROHS, CE
	Grilamid LV-50H FWA, reinforced fiberglass	KTW, ROHS, CE

PRESSURE DROP

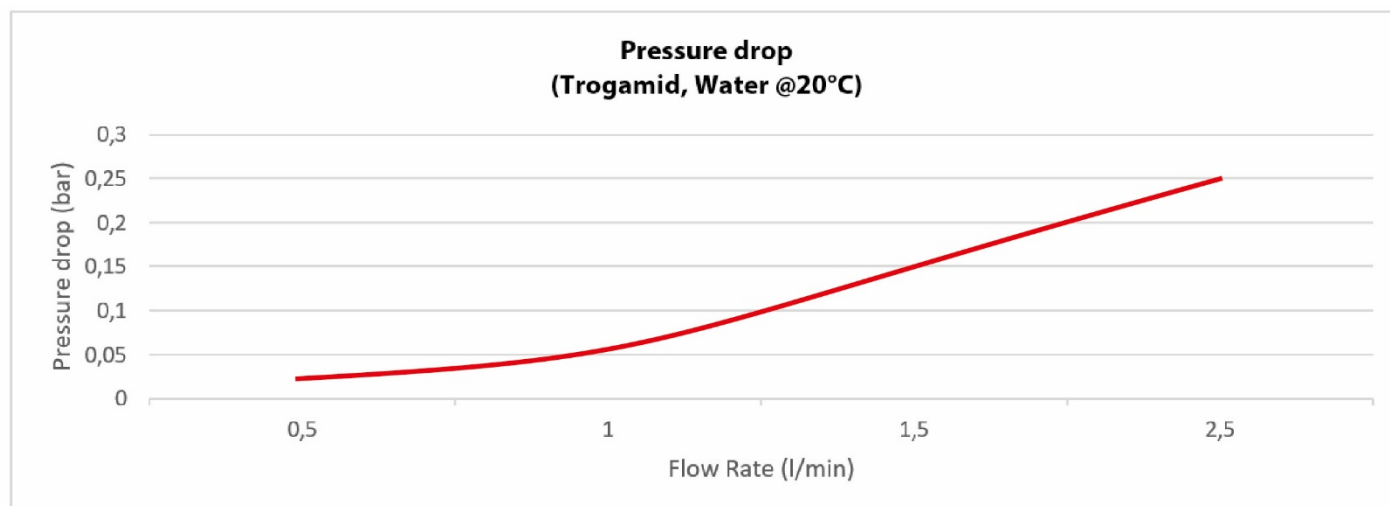

DRAWINGS

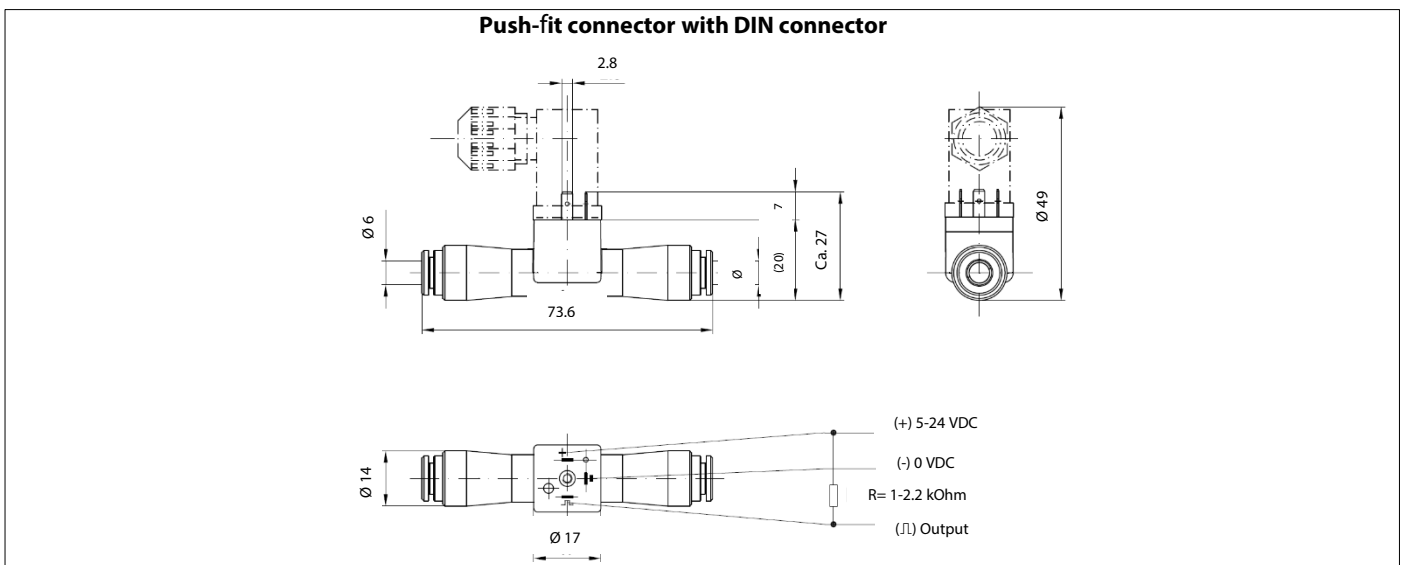
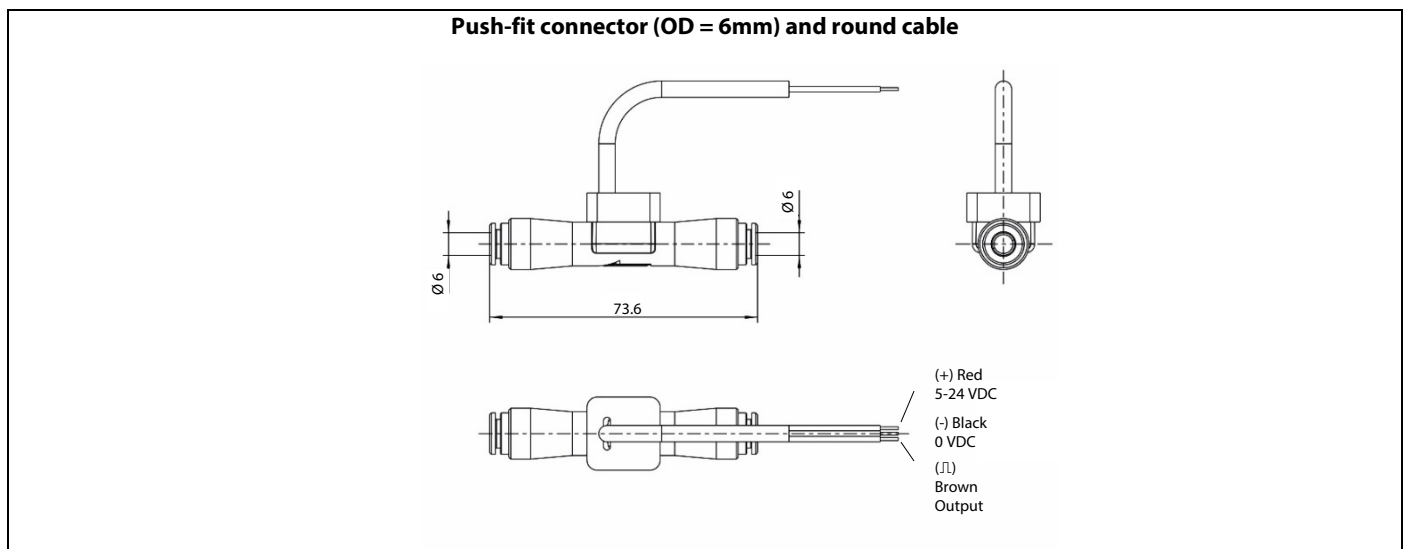
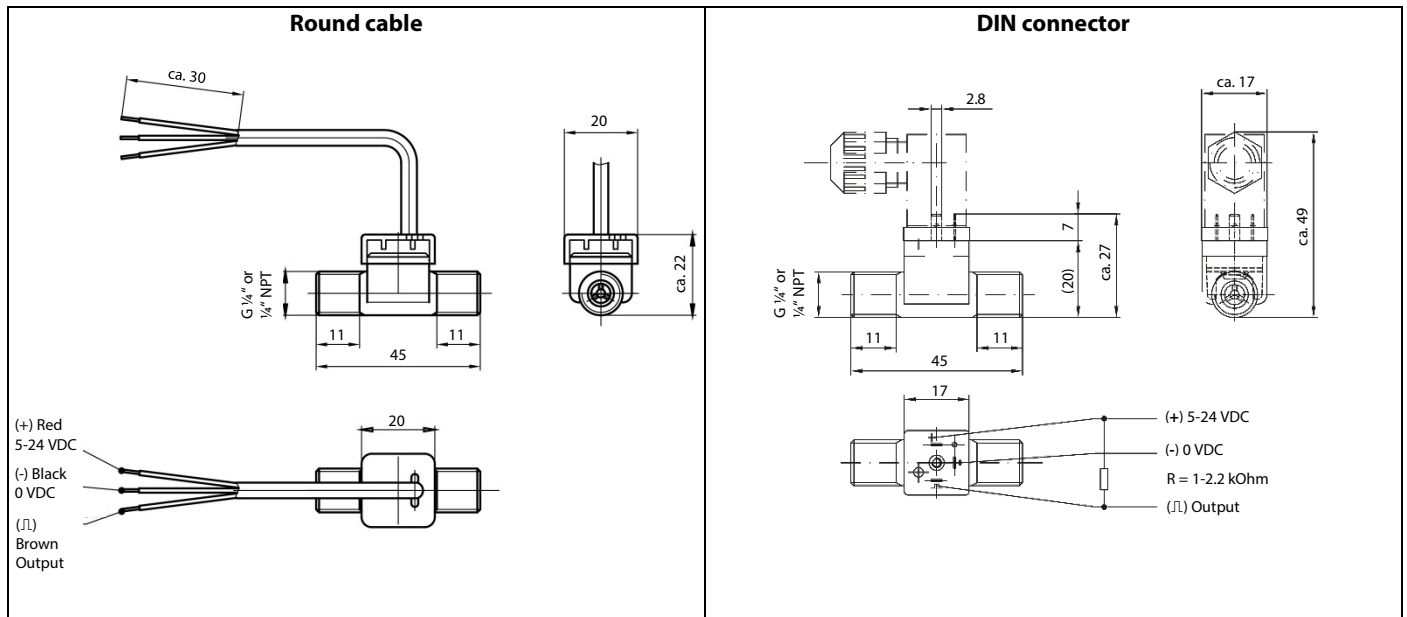

ELECTRICAL WIRING

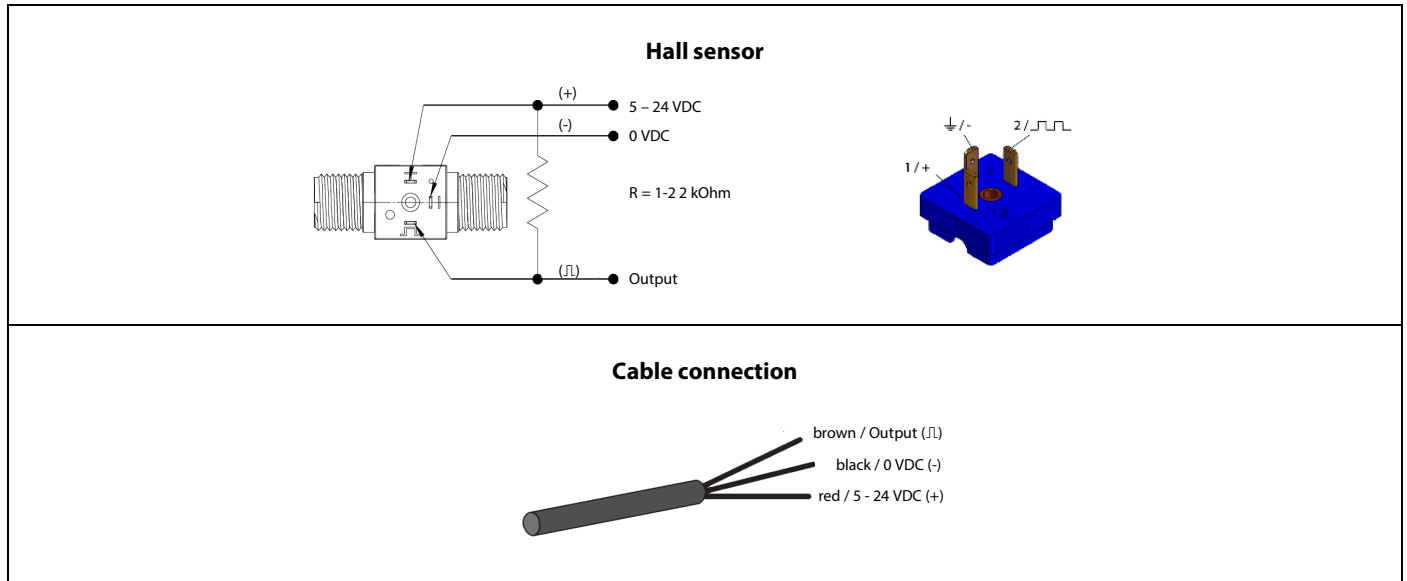

ORDERING MATRIX

Select process and electrical connection	Code				
Mechanical connector and body material:					
G 1/4" Trogamid	56547				
G 1/4" Stainless steel	56133				
G 1/4" Grilamid reinforced fiberglass	66129				
NPT 1/4" Trogamid	56548				
Push-fit OD = 6mm, Grilamid reinforced fiberglass	66136				
Electrical connection:					
DIN connector	-163				
Cable – select cable length, see option	-165				
Turbine model:					
	-2F66				
Option cable length:					
1 m	-1				
Examples:	Code				
VISION 1005 2F66 G1/4" Trogamid + DIN connector	56547	-163	-2F66		
VISION 1005 2F66 G1/4" Trogamid + 1m cable	56547	-165	-2F66	-1	

Control. Manage. Optimize.

Dynasonics, AquaCUE and SoloCUE are registered trademarks of Badger Meter, Inc. Other trademarks appearing in this document are the property of their respective entities. Due to continuous research, product improvements and enhancements, Badger Meter reserves the right to change product or system specifications without notice, except to the extent an outstanding contractual obligation exists. © 2021 Badger Meter, Inc. All rights reserved.