



Fittings and gauges optional

TECHNICAL DETAILS		APPLICATION AREA	DESCRIPTION
Material:	Brass or stainless steel (1.4404)	Depending on applied materials, this pressure regulator is applicable for different gases and liquids.	The line pressure regulator L 3/4 is characterised by an accurate regulation and a large throughput.
Valve seat:	Ø 10	We urgently recommend the connection of a fine filter with max. 40 µ at the inlet of the pressure regulator. Subsequent components and plant components must be protected by separate safety valves.	The spring loaded pressure regulator works according to the principle of the force equilibrium between the adjusted spring force and the outlet pressure.
Cv-value:	2,0		
Seat:	EPDM or FKM		It can be equipped optionally with an inlet and an outlet gauge.
Diaphragm:	EPDM or FKM		
Max. inlet pressure:	110 bar		
Outlet pressure ranges:	0,5 - 3 bar 0,5 - 6 bar 1 - 10 bar 1 - 20 bar 5 - 70 bar 5 - 100 bar		
Operating temp.:	-40°C to +150°C		
Dimensions:	Ø 93 x 186 mm		
Weight:	4,8 kg		
Connections:	Inlet / outlet G 3/4" or NPT 3/4" Gauge NPT 1/4"		

QUALITY STANDARD

The company Hornung is certified to **DIN EN ISO 9001:2015** and **ISO 14001:2015**. All single parts are manufactured, assembled and tested by in-house production. The finished parts are therefore under all criteria of German quality control with 100% final inspection.

L 3/4

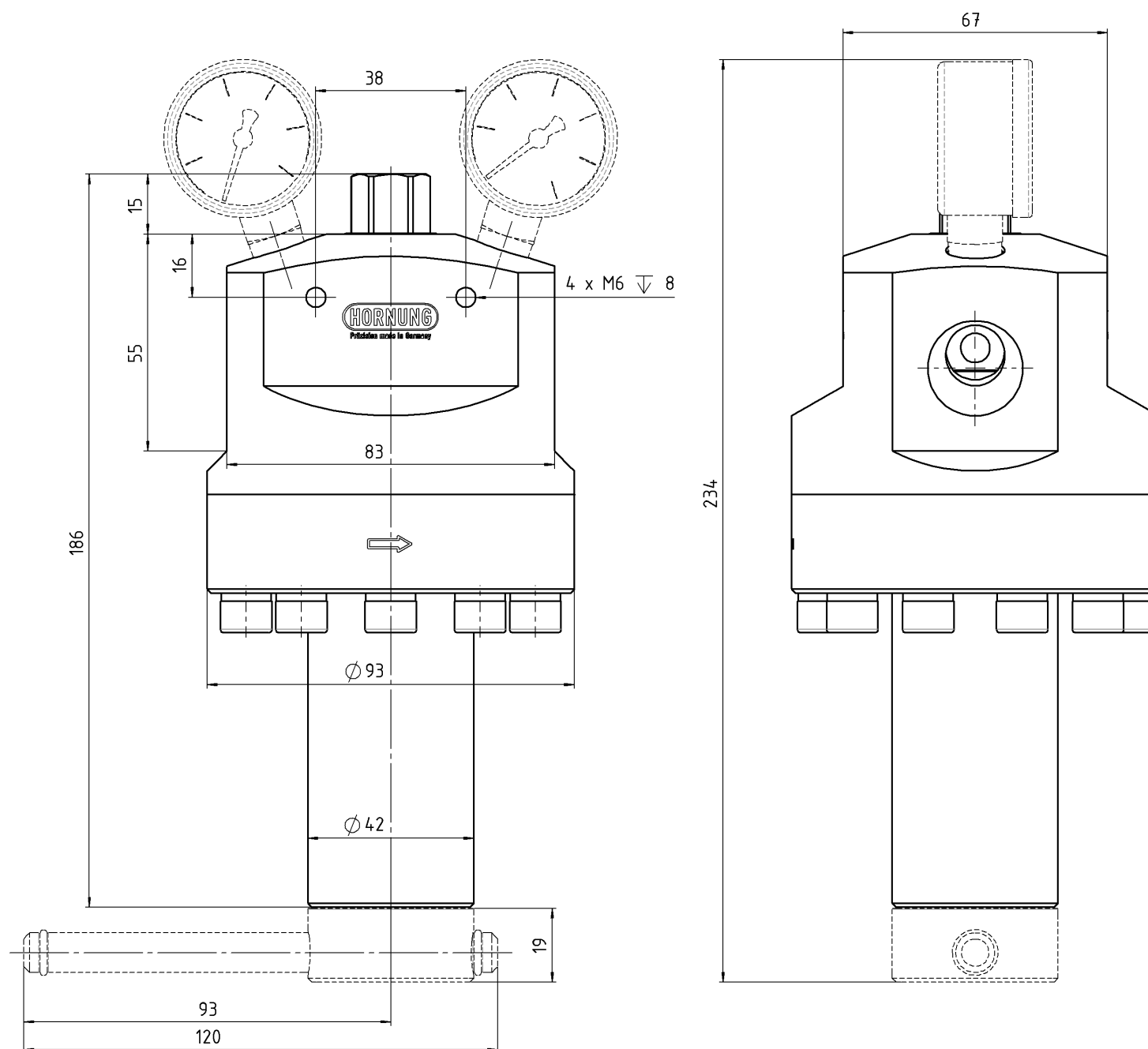

VERSION

A large independence from fluctuation of the inlet pressure is reached with a balanced poppet.

The use of high-grade steel in connection with elastomer made of FKM permits the application of this pressure regulator with aggressive media.

ORDER DETAILS

Material:	Diaphragm:	Outlet pressure P2:	Gauges:	Inlet / outlet:
1 = brass	1 = EPDM	1 = 0,5 - 3 bar	0 = none	0 = G 3/4" - Internal thread
2 = stainless steel	2 = FKM	2 = 0,5 - 6 bar	1 = with inlet and outlet gauge	1 = NPT 3/4" - Internal thread
		3 = 1 - 10 bar		
		4 = 1 - 20 bar		
		5 = 5 - 70 bar		
		6 = 5 - 100 bar		

Regulator type	330- Type	2 Material	1 Diaphragm	3 P2	1 Gauges	1 In-/outlet	Gas type Gas type
330- L 3/4							

Accessories: see total catalogue segment

- 7. Gauges, fittings and accessories
- 8. Fein filter F1, safety valves available on request