

Dome pressure regulator D 3/4



Fittings and gauges optional

TECHNICAL DETAILS		APPLICATION AREA	DESCRIPTION
Material:	Brass or stainless steel (1.4404)	The dome pressure regulator is used as a line pressure regulator.	Dome pressure regulators are characterized by an accurate regulation and a large throughput.
Valve seat:	Ø 10	Without exchanging parts it is suitable for a large outlet pressure range. Dependent on the used material, the pressure regulator is applicable for different gases and liquids.	The dome pressure regulator works according to the principle of the pressure balance between dome pressure and outlet pressure.
Cv-value:	2,0		A large independence from fluctuation of the inlet pressure is reached with a balanced poppet.
Seat:	EPDM or FKM	We urgently recommend the connection of a fine filter with max. 40 µ at the inlet of the pressure regulator. Subsequent components and plant components must be protected by separate safety valves.	If the dome pressure regulator is used for the pressure control of gases, the dome pressure can be controlled by needle valves.
Diaphragm:	EPDM or FKM		For the pressure regulation of liquids and aggressive gases, the dome can be filled with compressed air or nitrogen externally, by means of a pilot pressure regulator.
Max. inlet pressure:	110 bar		
Outlet pressure ranges:	up to 12 bar up to 100 bar		
Operating temp.:	-40°C to +150°C		
Dimensions:	Ø 93 x 129 mm		
Weight:	4,6 kg		
Connections:	Inlet / Outlet G 3/4" or NPT 3/4" Gauge NPT 1/4" Dome screw NPT 1/8"		

QUALITY STANDARD

The company Hornung is certified to **DIN EN ISO 9001:2015** and **ISO 14001:2015**. All single parts are manufactured, assembled and tested by in-house production. The finished parts are therefore under all criteria of German quality control with 100% final inspection.

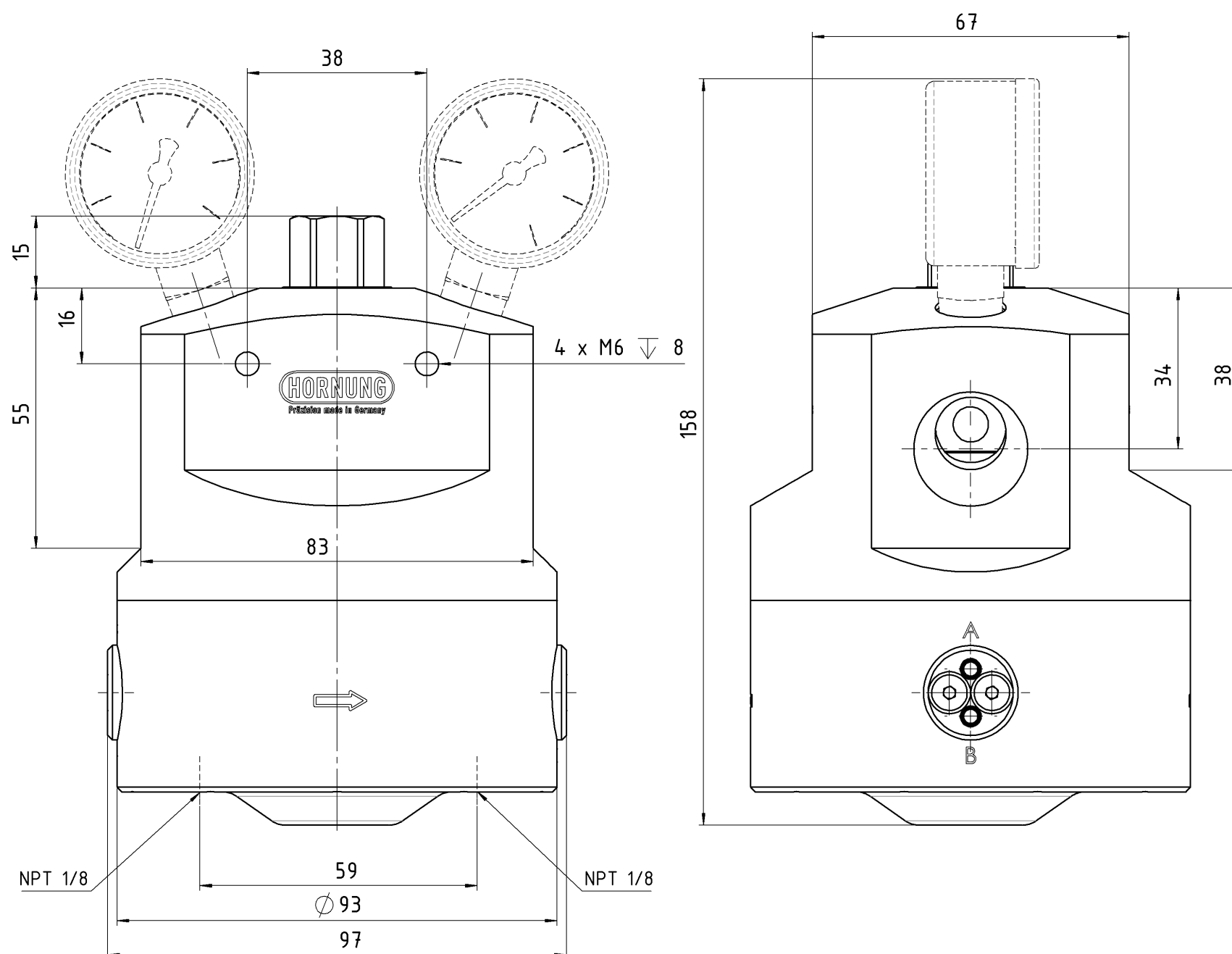

REGULATING WITH PILOT PRESSURE REGULATORS

If the outlet pressure is to be adjusted more frequently, set more precisely or controlled remotely, the use of a control valve is recommended. A control valve is attached instead of the plug at the dome of the pressure regulator.

Control valves are spring loaded pressure regulators, so called pilot regulators. When operating with dome pressure regulators of this size, our special P.I.D.-regulators with integrated pilot regulators or proportional valves are used.

DYNAMIC PRESSURE REGULATION

A dynamic pressure control is reached by means of an integrated needle valve in the dome of the pressure regulator.

By slightly releasing the control medium into the process gas line, the control medium is constantly re-feed. When using liquids in the pilot regulator, the control medium is slightly released into the atmosphere, which leads to a re-feed of the pilot regulator.

According to this function, the pressure inside of the dome can be held constant even in the event of temperature or flow variations.

ORDER DETAILS

Material/ pressure:

- 1 = brass 100 bar
- 2 = stainless steel 100 bar
- 3 = brass 12 bar
- 4 = stainless steel 12 bar

Diaphragm:

- 1 = EPDM
- 2 = FKM

Gauges:

- 0 = none
- 1 = with inlet and outlet gauge

Option at inlet / outlet:

- 0 = G 3/4" - internal thread
- 1 = NPT 3/4" - internal thread

Regulator type

320- D 3/4

320-
Type

2
Material/
pressure

1
Diaphragm

1
Gauges

0
In-/outlet

Gas type
Gas type

Accessories: see total catalogue segment

- 5. Pilot pressure regulators, flanges
- 7. Gauges, fittings and accessories
- 8. Fein filter F1, safety valves available on request

- 9. Wall mounting bracket