

# Dome pressure regulator DH 1



Fittings and gauges optional

TECHNICAL DETAILS		APPLICATION AREA	DESCRIPTION
Material:	Brass or stainless steel (1.4404)	The dome pressure regulator is used as a line pressure regulator.	Dome pressure regulators are characterised by an accurate regulation and a large throughput.
Valve seat:	Ø 12,7 (balanced)	Without exchanging parts it is suitable for a large outlet pressure range. Dependent on the used material, the pressure regulator is applicable for different gases and liquids.	The dome pressure regulator works according to the principle of the pressure balance between dome pressure and outlet pressure.
Cv-value:	3,0		A large independence from fluctuation of the inlet pressure is reached with a balanced poppet.
Seat:	PCTFE	We urgently recommend the connection of a fine filter with max. 40 µ at the inlet of the pressure regulator. Subsequent components and plant components must be protected by separate safety valves.	If the dome pressure regulator is used for the pressure control of gases, the dome pressure can be controlled by needle valves.
Membran:	EPDM / FKM		For the pressure regulation of liquids and aggressive gases, the dome can be filled externally with compressed air or nitrogen by means of a pilot pressure regulator.
Max. inlet pressure:	320 bar brass 420 bar stainless steel		
Outlet pressure range:	up to 300 bar brass up to 400 bar stainless steel		
Operating temp.:	-40°C to +150°C		
Size:	Ø 124 x 152 mm		
Weight:	9,3 kg		
Connections:	inlet / outlet NPT 1" or G 1" gauge NPT 1/4" dome-screw NPT 1/4"		

## QUALITY STANDARD

The company Hornung is certified to **DIN EN ISO 9001:2015** and **ISO 14001:2015**. All single parts are manufactured, assembled and tested by in-house production. The finished parts are therefore under all criteria of German quality control with 100% final inspection.

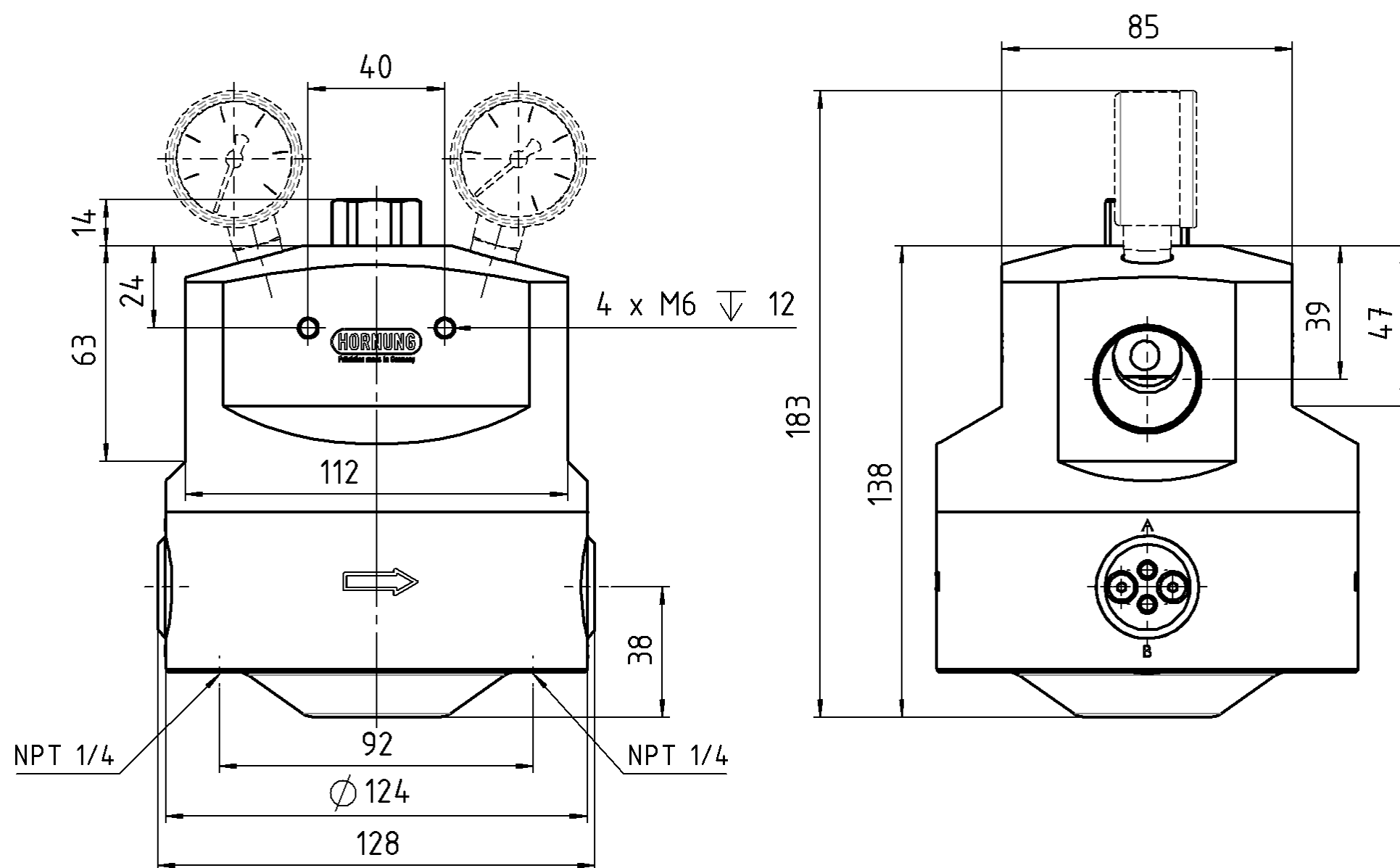

## REGULATING WITH PILOT PRESSURE REGULATORS

If the outlet pressure is to be adjusted more frequently, set more precisely or controlled remotely, the use of a control valve is recommended. A control valve is attached instead of the plug at the dome of the pressure regulator.

Control valves are spring loaded pressure regulators, so called pilot regulators. When operating with dome pressure regulators of this size, our special P.I.D.-regulators with integrated pilot regulators or proportional valves are used.

## DYNAMIC PRESSURE REGULATION

A dynamic pressure control is reached by means of an integrated needle valve in the dome of the pressure regulator. By slightly releasing the control medium into the process gas line, the control medium is constantly re-fed.

When using liquids in the pilot regulator, the control medium is slightly released into the atmosphere, which leads to a re-feed of the pilot regulator.

According to this function, the pressure inside of the dome can be held constant even in the event of temperature or flow variations.

## ORDER DETAILS

Material:	Diaphragm:	Gauges:	Option at inlet / outlet
1 = brass 300 bar	1 = EPDM	0 = none	0 = G1" - Internal thread
2 = stainless steel 400 bar	2 = FKM	1 = with inlet and outlet gauges	1 = NPT 1" - Internal thread

Regulator type	341- Typ	Material	Diaphragm	Gauge	Option	Gas type
341 DH 1	1	1	1	0	Gas type	

### Accessories:

- Pilot regulator, flanges, gauges, tube fittings und accessories
- Fine filter F1 (see data sheet), safety valves available on request